

# Combination Smoke and Heat Detector

## U-313



### Operation Theory

This Product is a Combination Smoke and Heat Detector. Which Runs by Detecting Smoke Particles. Adopted Special Structure Design, and Photoelectric Signal Processing Technique, It Has The Functions of Dustproof, Mothproof, and Anti-Electromagnetic Interference, The Stability of the Product is Assured From the Above. It Performs Well in Detecting Visible Smoke Caused by Hidden or Bright Fire. It's Suitable for Detecting Smoke in Houses, Stores, Hotels, and Warehouses, etc.

### Characteristics

- High Stability Smoke Chamber and NTC Heat Sensor
- Low Power Consumption MCU, High Reliability Intelligent Algorithm of Smoke and Heat
- High Adaptability to the Ambient, With Dustproof, Mothproof, Moisture Proof and High EMI Immunity
- Orientation Differences:  $M_{max} : M_{min} < 1.6$
- Highlight Dual Color LED Indication
- Tamper Switch
- Unique Bracket Design, Easy Installation

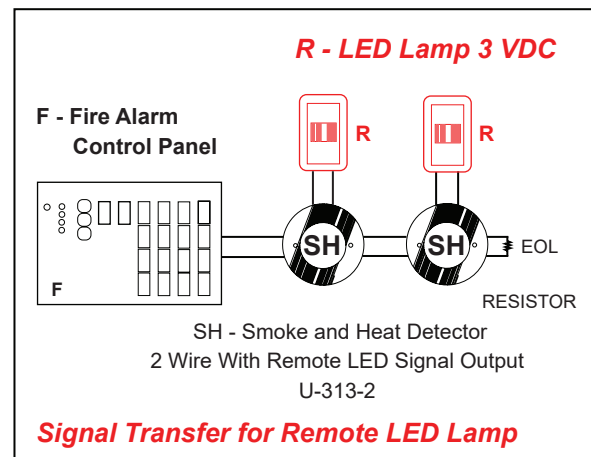

### Specifications

Model / Product	U-313-2 / Combination Smoke and Heat Detector
Input Voltage	9 - 28 VDC
Static Current	50 ± 5 uA (24 VDC)
Alarm Current	55 ± 5 mA (24 VDC)
Operating Temperature	-10 °C ~ + 55 °C
Operating Humidity	10% - 95% RH (Non Coagulating)
Installation	Ceiling Mounted
Output / Wiring Mode	3 VDC Remote Indicator Lamp / 2 Wire With Remote LED Signal Output
Alarm Temperature	Fixed Temperature: 57 / 137 °F & Rate-of-Rise: 8-15 °C / Min
Alarm Reset	Power Off Reset
LED Indication	Detecting: Green LED Flash / Alarm: Red LED ON
Material / Color	ABS Plastic / White Color
Dimension	∅ 100 X 45 mm.

### Effective Alert Area

Construction Height	4 m
Fireproof Building	60 m <sup>2</sup>